

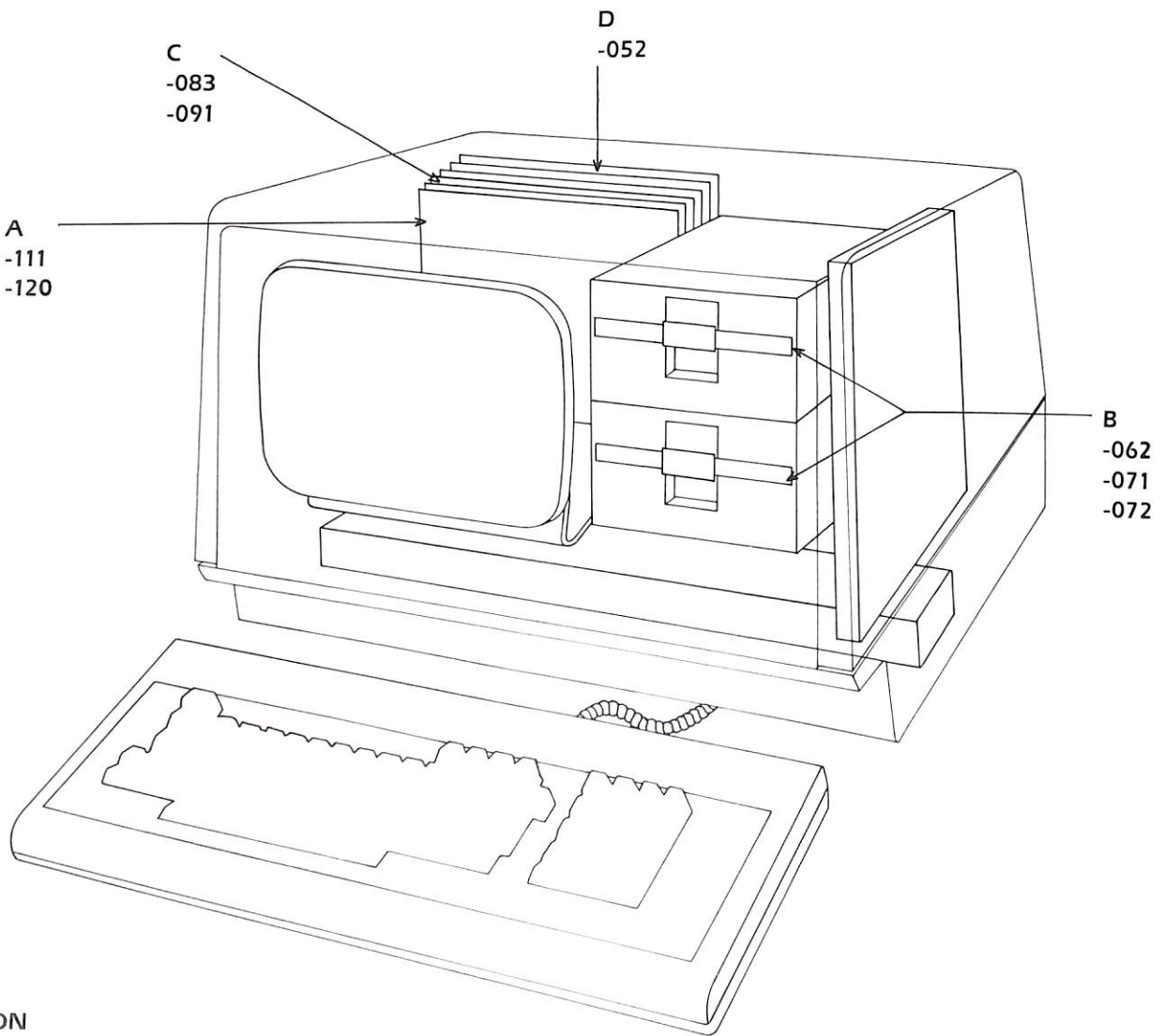

INTERNATIONAL
CD100M
MULTIBUS*
COMPATIBLE PRODUCTS
PRICE LIST





CONFIGURATION

A (CHOOSE 1)

B (CHOOSE 1)

C (CHOOSE 1 OR BOTH)

D OPTIONAL

Order No.	Description	Price
	WORKSTATIONS	
CD100M-420	CD100 Integrated Workstation including advanced video controller (ANSI compatible) with RS232 interface; 25 line x 80 char/line display; six slot Multibus card cage; 200 watt switching power supply; 83 key detachable keyboard with numeric keypad. Includes CD100M User's Manual.	\$3295
	PROCESSOR OPTIONS	
-111	Z80B 8-bit CPU (6 MHz) with 64K bytes of dual port dynamic RAM and three serial I/O ports. Requires one slot.	\$1045
-120	8086 16-bit CPU (8 MHz); 256K bytes dynamic RAM with error detection/correction. Has 24 parallel I/O lines and one serial port. Also, has three programmable interval timers, a programmable interrupt controller and 32K byte ROM/EPROM sockets. A two board configuration.	\$4785
	DISK MEMORY OPTIONS	
-062	Dual 5.25-inch minifloppies with 1.2M byte (formatted) storage. Double-sided, double-density (96 TPI). Mini-floppy controller is required.	\$1535
-071	Combination 5.25-inch minifloppy with 600K byte (formatted) storage and 5.25-inch Winchester hard disk drive with 5M byte (formatted) storage. One minifloppy controller board and one Winchester controller board are required.	\$2805
-072	Combination 5.25-inch minifloppy with 600K byte (formatted) storage and 5.25-inch Winchester hard disk drive with 12.6M byte (formatted) storage. One minifloppy controller board and one Winchester controller board are required.	\$3740
	DISK CONTROLLER OPTIONS	
-083	High performance minifloppy controller with 1M byte addressability with DMA. Capable of supporting up to four disk drives (8-inch or 5-inch) and is Intel SBC* 208 software-compatible. For use in all floppy-based systems (options -062, -071 and -072).	\$825
-091	High performance Winchester controller with 1M byte addressability with DMA and 256 byte or 512 byte sectors. Has multiple sector read/write and fully automatic and transparent burst error detection and correction. Required for use with option -071 or -072.	\$1535
	MISCELLANEOUS OPTIONS	
-052	Graphics controller board. Allows terminal portion of the system to act as a graphics terminal. Is Tektronix 4010-compatible with added features such as two full 1024 X 1024 display buffers (not part of main memory), down-loadable character set, ZOOM, PAN, scale, area fill and point plotting. (Availability to be announced)	\$1595
-033	Heavy duty power supply including +12 volt output for Winchester/floppy combination. Also includes power cables and mounting cables and mounting brackets (does not include bezel coverplate). Standard equipment with -071 or -072 options.	\$275
-001	P2 Multibus* extension with six slots. Allows address extension to 16M bytes and provides AC Low (power fail) detection and interrupt generation logic.	\$385
-002	P2 connector wirewrap kit. Six wirewrap connectors with threaded inserts.	\$127
-343	CD100M User's Manual (included with CD100M).	\$55
-344	CD100M Maintenance Manual.	\$138
	OPERATING SYSTEMS	
-210	CP/M-80* general purpose control program including dynamic file manager; an 8080 assembler; a general purpose editor; a dynamic debugger; Basic I/O System (BIOS) including drivers for minifloppy controllers (option -083) and Winchester controller (option -091). Complete documentation package included. Requires option -111.	\$400
-220	CP/M-86* general purpose control program for 8086 CPU including a dynamic file manager; 8086 assembler; interactive debugger; an editor; BIOS including drivers for minifloppy controller (option -083) and Winchester controller (option -091). Complete documentation package included. Requires option -120.	\$500
	LANGUAGES	
-217	CBASIC. Basic Programming compiler for use under CP/M-80. Allows higher level language programming. Requires Option -210.	\$125
-221	CBASIC/86. Basic Programming compiler for use under CP/M-86. Allows higher level language programming. Requires Option -220.	\$325

APPLICATION SOFTWARE		
-211	WordStar* screen-oriented word processing system for text entry and alteration. Features include video editing; on-screen text formatting; automatic disk buffering; help system; hyphen help; and additional print enhancements. Requires option -210.	\$500
-212	MailMerge* WordStar option allowing production of form letters combining data from multiple files. Supports nested and chained printing. Complete documentation package included. Requires option -211 WordStar.	\$150
-213	DataStar* comprehensive data entry retrieval and update system. Features include help system, flexible data entry format, field verification and edit masking, search/retrieval operation and batch verification processing. Complete documentation package included. Requires option -210.	\$350
-214	SuperSort* program for high performance and flexible sorting, merging, and record selection. Complete documentation package included. Requires option -210.	\$250
-215	SpellStar* WordStar option performs automatic spelling check of text written under the WordStar word processing package. Includes 20,000 character dictionary and allows additions to the dictionary for special industries. Flags unknown words for possible correction or verification.	\$250
-216	CalcStar* program for electronic worksheet use. Allows an electronic spreadsheet to be created with labeled columns and rows. Individual items can be the result of sophisticated processing of other items in the spreadsheet. Has print output capability. Requires -210.	\$295

TERMS AND CONDITIONS OF PURCHASE AND SALE

Any offer to acquire products listed herein and any sale of products by Callan Data Systems will be made on the terms and conditions that follow. Callan Data Systems hereby specifically rejects any terms and conditions on Buyer's offer in conflict with or in addition to these terms and conditions. Buyer's offer will not be deemed accepted until Callan Data Systems has issued a written acknowledgement.

Prices and Orders:

All prices are FOB Westlake Village, CA. Prices do not include taxes or duties. Delivery schedules shall be mutually agreed to. If Buyer does not purchase the entire quantity upon which the quoted prices were based, Buyer agrees to pay the specified higher price for the quantity actually purchased.

Terms of Payment:

Qualified customers with credit approval by Callan Data Systems: 2% 10 days, Net 30 days from date of invoice.

All others: 50% with order; 50% with delivery.

Callan Data Systems may change these credit terms if Buyer's financial condition changes. Each shipment shall be considered a separate and independent transaction.

Title and Delivery:

All shipments are FOB point of shipment. Title and risk of loss pass to Buyer upon delivery to carrier at shipping point. Callan Data Systems will select the shipping carrier if Buyer does not. Claims for shortages must be made within ten (10) days of arrival.

Warranty:

Callan Data System's products are warranted against defects in materials and workmanship for a period of nine months from date of original shipment. Callan Data Systems will at its option, repair or replace system modules which prove to be defective during the warranty period. If equipment fails during the warranty period, Buyer shall notify Callan Data Systems and request a Return Material Authorization. The defective system module should then be returned with a failure report attached to Callan Data Systems, freight prepaid, and it will either be repaired or replaced at the option of Callan Data Systems and returned to the customer freight prepaid. Repairs necessitated by shipping damage, misuse of the equipment, or by hardware, software, or interfacing not provided by Callan Data Systems are not covered by this warranty.

EXCLUSIONS OF WARRANTIES: THE IMPLIED WARRANTIES OF MERCHANTABILITY AND FITNESS FOR A PARTICULAR PURPOSE AND ALL OTHER WARRANTIES, EXPRESS OR IMPLIED, EXCEPT AS SET FORTH IN THIS WARRANTY SHALL NOT APPLY TO THE PRODUCTS DELIVERED. CALLAN DATA SYSTEMS NEITHER ASSUMES NOR AUTHORIZES ANY OTHER PERSON TO ASSUME ANY OTHER LIABILITIES IN CONNECTION WITH THE SALE OR USE OF ANY PRODUCT.

Limitation of Liability:

IN NO EVENT SHALL CALLAN DATA SYSTEMS BE LIABLE FOR ANY REPROCUREMENT COSTS, LOSS OF PROFITS, LOSS OF USE, INCIDENTAL, CONSEQUENTIAL OR SPECIAL DAMAGES.



DATA SYSTEMS

2645 Townsgate Road
Westlake Village, CA 91361
(805) 497-6837
(800) 235-7055
FAX (910) 336-1085

ALL CALLAN TRADEMARKS OF CALLAN DATA SYSTEMS
WORDSTAR MAILMERGE SUPER SORT SPELLSTAR DATASTAR
REPRODUCTION OF WORDSTAR AND CALCSTAR IS PROHIBITED
© 1982 CALLAN DATA SYSTEMS, INC.